

WABO® COMPRESSIONSEAL

DESCRIPTION:

The Wabo® CompressionSeal Heavy Duty series is a preformed elastic joint seal manufactured of neoprene and installed with a lubricant adhesive. It is highly resistant to deterioration from exposure to weather, sunlight, oils, and impact. When properly installed, the Wabo® CompressionSeal Heavy-Duty series provides a permanent seal for any type construction whether in bridges, parking decks, or buildings. Featuring an internal elastomeric cross-sectional web configuration, the seal design allows it to exert a continuous and uniform force against the joint walls therefore effectively preserving water tightness. Even at the lowest design temperature, the seal will retain its elasticity while maintaining a minimum of 15% compression to assure a dependable seal. The Wabo® CompressionSeal Heavy Duty series has proven itself to be an effective and efficient seal in resisting the differential movements and extreme conditions found in high impact structures.

FEATURES / BENEFITS:

- Unique Design**
 The Wabo® CompressionSeal Heavy Duty series design configuration enables the entire seal to act as an integral unit resisting compressive forces without distorting the sides. This keeps the walls in uniform contact to achieve a watertight joint. Also, the design prevents the seal from being forced out of the joint and extending above the surface.
- Ease of Installation**
 The lubricant adhesive facilitates the Wabo® CompressionSeal Heavy Duty series installation process and provides a vehicle to give intimate contact with the joint wall by filling minor voids in the joint interfaces.

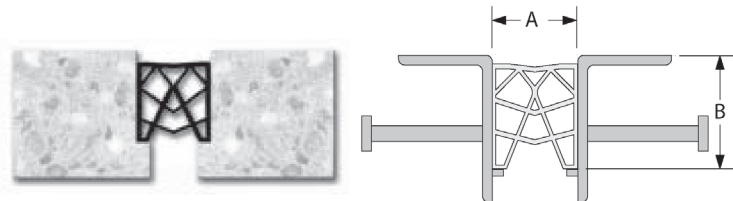

Model	Movement	Seal Size		Groove Width		Groove Depth B	Installation Width
		Width	Height	Min.A	Max.A		
WA-175	.800"	1 3/4"	2"	.687"	1.487"	2 5/8"	1"
WA-200	.825"	2"	2"	.875"	1.7"	2 5/8"	1 1/4"
WA-250	1.125"	2 1/2"	2 3/4"	1"	2.125"	3 9/16"	1 1/2"
WA-300	1.425"	3"	3 3/8"	1.125"	2.55"	4 5/16"	1 3/4"
WA-350	1.6"	3 1/2"	3 1/2"	1.375"	2.975"	4 7/16"	2 1/4"
WA-400	1.775"	4"	4 3/8"	1.625"	3.4"	5"	2 1/2"
WA-500	2.563"	5"	5"	1.687"	4.25"	5 15/16"	3"
WA-600	3.1"	6"	6"	2"	5.1"	7 3/4"	3 1/2"
WG-200	.950"	2"	1 1/4"	.75"	1.70"	1 1/2"	1 1/4"
WG-300	1.380"	3"	2 1/2"	1.17"	2.55"	3 1/8"	1 7/8"
WG-325	1.575"	3 1/4"	3 1/8"	1.185"	2.76"	3 3/4"	2"
WG-400	1.750"	4"	2 1/2"	1.65"	3.40"	3 1/8"	2 9/16"
WG-500	2.370"	5"	3 1/4"	1.88"	4.25"	4"	3 1/16"

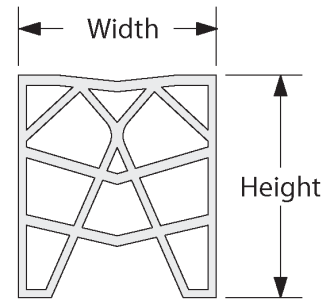

WA Series

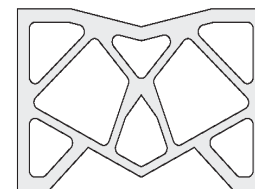

WG Series

PACKAGING & COVERAGE

CompressionSeal—Longest available length provided from manufacturer.

Prime-A-Lub Adhesive—Available in 1 gal. container.

Coverage: 1 1/4"-3 1/2" seal width = 200' per gal.
Greater than 3 1/2" seal width=100' per gallon

WATSON-BOWMAN-ACME