

## A-21-X Flat Tie

Dayton/Richmond A-21-X Flat Tie is used with the A-51 Wedge Bolt to secure and space modular forms. A-21-X ties are available in 6" through 24" in 1/2" increments. Standard breakback is 1/4".

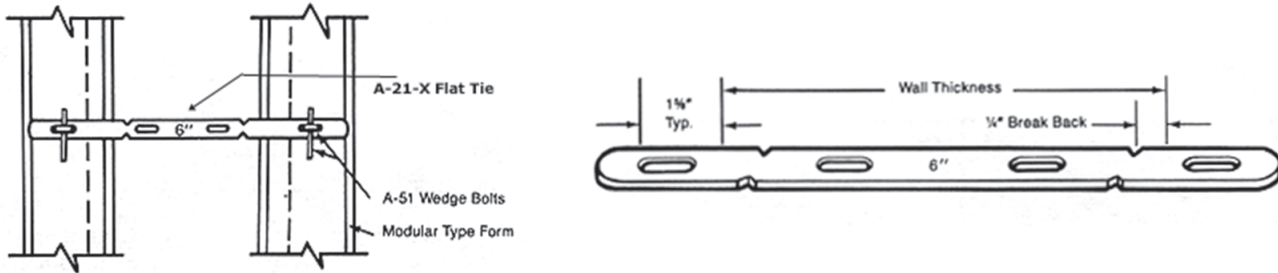

**PACKAGING**  
 100 ties per bundle.  
 Standard inventoried sizes include 8", 10", 12", 14", 16", and 18"

## A-46 Loop Panel Tie, Standard and Heavy

Dayton/Richmond A-46 Loop Panel Ties are designed for securing and spacing modular type forms. Standard units are fabricated with 2-1/8" ends and 1" breakback. When erecting modular type forms, the A-46 ties are placed in the slots between the form panels. An A-51 Wedge Bolt is placed through the adjoining form and into the loop of each tie. A second wedge bolt is then placed through the slot of the first wedge bolt to secure the tie and form together.

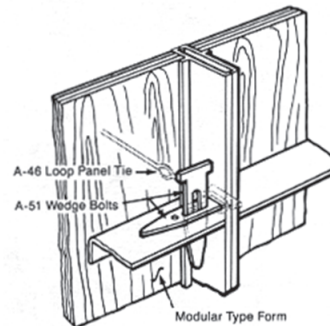
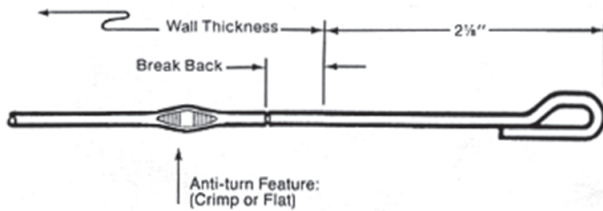

**PACKAGING**  
 100 ties per bundle.  
 Standard inventoried sizes include 8", 10", 12"

## A-51 Wedge Bolt



**PACKAGING**  
 500 per bundle